



# INSTRUCTION BULLETIN

No. 9013142  
Machine: S30  
Published: 01-2017  
Rev. 01

**NOTE: DO NOT DISCARD the Parts List from the Instruction Bulletin. Place the Parts List in the appropriate place in the machine manual for future reference. Retaining the Parts List will make it easier to reorder individual parts and will save the cost of ordering an entire kit.**

*NOTE: Numbers in parenthesis ( ) are reference numbers for parts listed in Bill of Materials.*

Installation instructions for **kit number 9013141**

## SYNOPSIS:

This kit contains the parts needed to replace the front bumper on S30 sweepers (serial numbers 000000 - 006500) equipped with either steel or plastic hoppers. Please follow step-by-step instructions.

## SPECIAL TOOLS / CONSIDERATIONS: NONE

(Estimated time to complete: 2 hours)

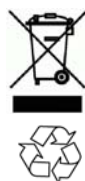

### PROTECT THE ENVIRONMENT

Please dispose of packaging materials, used machine components such as batteries and fluids in an environmentally safe way according to local waste disposal regulations.

Always remember to recycle.

## PREPARATION:

1. Park the machine on a clean level surface, turn off the machine, set the parking brake, and remove the key.

**FOR SAFETY: Before leaving or servicing machine, stop on level surface, turn off machine, set parking brake, and remove key.**

2. Lift the front shroud open and engage the prop rod to secure the front shroud in the raised position.
3. Open the hopper access door.
4. **Machines equipped with optional side brush(es) only:** Remove the hardware securing the side brush(es) to the front bumper and carefully lower the side brush(es) to the floor. **Do not** break any hydraulic hose connections when removing the side brush(es) from the front bumper. Set the mounting hardware aside.

## INSTALLATION:

*NOTE: Use care when removing the old front bumper from the machine / installing the new front bumper (1) onto the machine. If necessary, seek help to remove the old front bumper / install the new bumper.*

1. Use jack stands or another means to hold the front bumper to the machine so the front bumper does not fall to the floor when the hardware securing the front bumper to the machine is removed in the following step.

**2. Machines equipped with steel hoppers:**

Remove the hardware securing the front bumper to the machine. Set the hopper support plates aside. Discard the spacer plates and hardware. (Fig. 1)

**3. Machines equipped with plastic hoppers:**

Remove the hardware securing the front bumper to the hopper and hopper support plates. Discard the hardware. (Fig. 1)

4. Remove the front bumper from the machine. (Fig. 1)

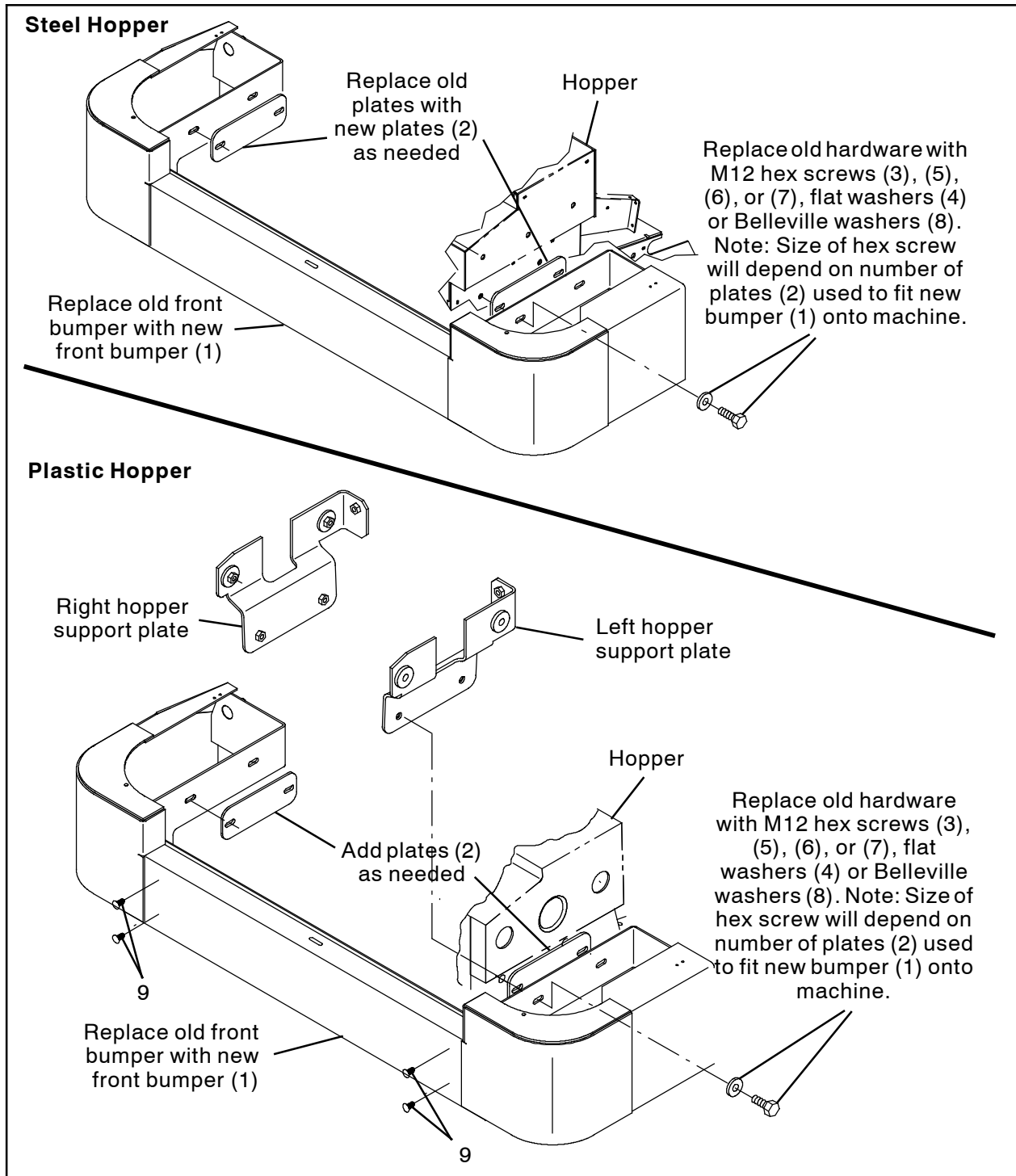

**FIG. 1**

- Remove the front shroud latch assemblies from both sides of the front bumper. Set the latch assemblies and all hardware aside. Discard the front bumper. (Fig. 2)

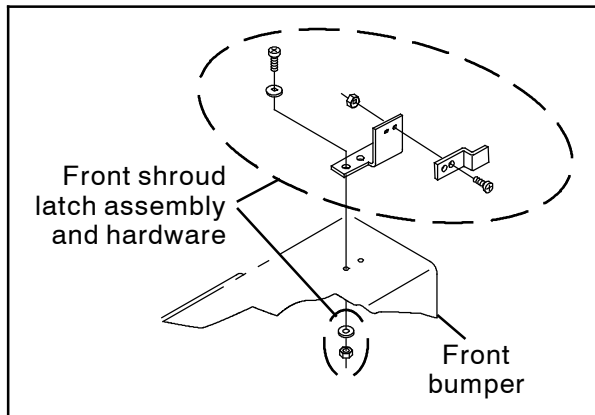

FIG. 2

- Use jack stands or another means to hold the new front bumper (1) to the machine.
- Install the new front bumper (1) onto the machine. Use the plates (2), M12 hex screws (3), (5), (6), or (7), flat washers (4) or Belleville washers (8). Use plates as necessary to fit the front bumper onto the machine. Size of hex screws will depend on the number of plates (2) used to fit the new bumper (1). (Fig. 1)
- Insert the hole plugs (9) into the front bumper (1). (Fig. 1)
- Install the front shroud latch assemblies onto the front bumper (1).
- Machines equipped with optional side brush(es) only:** Reinstall the side brush(es) onto the front bumper.

**Bill Of Materials For Bumper Kit, Hppr [S30] - 9013141**

	Tennant			
Ref.	Part No.	Description		Qty.
▽	9013141	Bumper Kit, Hppr, [S30]		1
▲	1 1212410	Bumper Wldt, Front		1
▲	2 1046928	Plate		4
▲	3 69972	Screw, Hex, M12 X 1.75 X 40, 10.9		4
▲	4 32493	Washer, Flat, 0.50, Std		4
▲	5 06971	Screw, Hex, M12 X 1.75 X 50, 8.8		4
▲	6 06972	Screw, Hex, M12 X 1.75 X 60, 8.8		4
▲	7 06970	Screw, Hex, M12 X 1.75 X 45, 8.8		4
▲	8 36328	Washer, Flat, Belleville, .50		4
▲	9 21168	Plug, Hole, Rnd, 0.25h 0.8l, Brb, Nyl		4

TENNANT COMPANY  
P. O. Box 1452  
Minneapolis, MN 55440-1452